

TYPHOON®

**FOOT  
VALVE**

---

 **tayfur**  
su sistemleri



# We Care Every Drop of Water...

That is why our company, which has been developing products in the field of water systems for over 20 years, offers increasingly efficient solutions every day. With our expertise and experience, we continue to develop innovative technologies for the proper control and sustainable use of water.

## OUR PRODUCTION CAPACITY IS INCREASING! OUR GOALS ARE BIGGER!

We have been wherever there is water since 2004.

Founded in Izmir by Tayfun Yazarođlu, TAYFUR WATER SYSTEMS set out with the belief that water is the source of life. Beginning with the production of hydraulic control valves, this journey has now transformed into a strong and reliable brand offering innovative solutions across a wide range of areas, including irrigation, drinking water, firefighting and industrial systems.

In every project, while determining the direction of water, we are also shaping the sustainable infrastructure of the future. From production to project design, from installation to technical support, we work without compromising on high quality standards, with our state-of-the-art facilities and expert team. We aim to offer our customers not just products, but also trust, continuity and technical excellence.

TYPHOON branded products are developed entirely with our own production capabilities and local engineering expertise. These products stand out not only for their durability, but also for our philosophy of preserving the value of every drop. Thanks to our production processes that comply with international standards and our customer satisfaction-focused approach, we are proud to be recognised as a reliable business partner both domestically and globally.

Today, TAYFUR WATER SYSTEMS, a brand with roots in Izmir, continues on its path with the vision of being a symbol of quality, innovation, and trust wherever water is present.





## *Agricultural Irrigation Systems*

The foundation of efficient agricultural production lies in delivering water at the right time, in the right quantity, and to the right location. Modern agricultural irrigation systems ensure both the efficient use of water resources and an increase in product quality and yield. The solutions developed in this context enable farmers to achieve a sustainable production structure independent of climatic conditions.

At TAYFUR WATER SYSTEMS, with our many years of engineering experience in the field of agricultural irrigation, we manufacture critical components such as hydraulic control valves, suction valves, backwash valves and meters to high quality standards. Each of our products saves energy by increasing the automation capabilities of the systems, prevents water wastage and minimises maintenance requirements. Thus, we offer reliable and long-lasting solutions for both small-scale businesses and large agricultural projects.

The products we develop are designed in accordance with international standards and tested to deliver maximum performance in challenging field conditions. At TAYFUR WATER SYSTEMS, our goal is to provide smart, durable, and sustainable systems for producers who value every drop. Because we believe that by determining the direction of water, we are shaping the future of agriculture.



## *Industrial Area Systems*

Proper water management in industrial facilities is critical to the efficiency and sustainability of production processes. Every application, from pressurised lines to cooling circuits, fire systems to process lines, requires precise control and high durability. Therefore, the performance of equipment used in industrial systems is directly related to facility safety and operational continuity.

At TAYFUR WATER SYSTEMS, we manufacture products that play a critical role in industrial applications, such as hydraulic control valves, backwash valves, vacuum breakers, and meters, to high engineering standards. Our products adapt to harsh working conditions with their high pressure resistance, corrosion resistance, and long service life. By providing complete control over fluid management, they increase energy efficiency in systems and minimise maintenance times.

Designed to comply with international standards, our solutions are trusted across a wide range of applications, from factories to power plants, water treatment facilities to infrastructure projects. At TAYFUR WATER SYSTEMS, our goal is to make industrial water management smarter, safer and more sustainable, providing our customers with the assurance of uninterrupted operations.



## *Fire Systems*

Fire safety is one of the most vital elements of every structure, from industrial facilities to public buildings, infrastructure projects to living spaces. The reliability of the equipment used in these systems is critical not only for the protection of the facility but also for the protection of human life.

As TAYFUR WATER SYSTEMS, we are a company specialising in the production of hydraulic control valves to ensure maximum safety in fire lines. Our products are designed to guarantee the fast, reliable and uninterrupted operation of fire systems. These valves, which stand out for their high pressure resistance, leak-proof performance and long service life, are tested in accordance with international standards and offered with quality assurance.

With our advanced engineering infrastructure and production experience, we produce solutions that can be used safely in various applications, from automatic sprinkler systems to fire pump stations. At TAYFUR WATER SYSTEMS, our goal is not just to manufacture products; it is to be part of systems that make a difference in fire safety, inspire confidence, and protect life.



## *Filter Automation*

Water is a vital resource that must be managed with maximum efficiency during the filtration stage, as it is in many industrial and agricultural processes. Proper automation in filtration systems is critical in terms of energy savings, ease of maintenance, and system continuity. An effective filter automation system determines not only the quality of the water but also the lifespan and efficiency of the entire system.

At TAYFUR WATER SYSTEMS, we offer comprehensive solutions in the field of filter automation. Our products, such as hydraulic control valves, backwash valves and panels, bottom valves, and dirt traps, ensure precise flow management in automatic filter systems. Our products optimise the water filtration process while performing backwashing operations precisely and efficiently. This reduces the risk of clogging in systems, prevents energy losses, and extends maintenance intervals.

All our products stand out with their durable material construction, precise control capability, and long-lasting design. At TAYFUR WATER SYSTEMS, our goal is to provide our customers with smart, reliable, and sustainable automation solutions by maximising efficiency in filtration processes. Because we believe that water purity begins with system safety.

# Foot Valve



The foot valve is a reliable control element designed to prevent backflow and maintain line pressure in pump systems. It prevents backflow when the pump is shut off, increasing system efficiency and preventing equipment damage. Its precision valve mechanism provides rapid response and ensures a quiet, impact-free, and completely leak-proof closing.

The filter function located at the valve inlet prevents foreign or harmful particles from entering the system. This extends the life of the pump and valve components and reduces system maintenance requirements.

With its durable body and flow-compatible internal design, the foot valve demonstrates high performance in both clean water and agricultural irrigation systems. Its long-lasting, safe, and low-maintenance design makes it an ideal solution for all types of pump suction lines.

## Order Information

Please provide the following information in case of order

- Maximum flow rate : m<sup>3</sup>/h
- Maximum network/operating pressure : bar
- Main pipeline diameter : mm



# Foot Valve

Sizes										Weight	
DN		D		D1		D2		H		lbs	kg
inch	mm	inch	mm	inch	mm	inch	mm	inch	mm		
2	50	6,50	165	9,84	250	7,24	184	10,98	279	38,39	17,45
2 ½	65	7,28	185	9,84	250	7,24	184	10,98	279	41,25	18,75
3	80	7,87	200	11,02	280	8,58	218	13,11	333	51,59	23,45
4	100	8,66	220	11,02	280	8,58	218	13,11	333	51,92	23,60
5	125	9,84	250	12,60	320	10,00	254	14,09	358	72,38	32,90
6	150	11,22	285	13,39	340	10,79	274	15,67	398	98,34	44,70
8	200	13,39	340	16,14	410	13,07	332	20,47	520	165,00	75,00
10	250	15,94	405	18,11	460	13,86	352	21,89	556	209,00	95,00
12	300	18,11	460	20,47	520	15,98	406	25,83	656	240,24	109,20
16	400	22,83	580	25,20	640	20,87	530	28,58	726	374,00	170,00
20	500	28,15	715	30,51	775	20,87	530	30,31	770	583	265,00

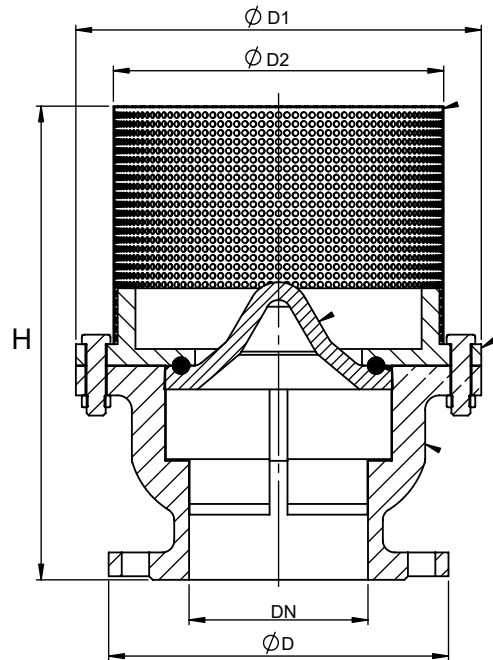

#	Material Name	Type of Material
1	Body	GGG40
2	Oring	NBR
3	Flap	GGG40
4	Oring	NBR
5	Cover	GGG40
6	Washer	8.8 Coated Steel
7	Bolt	8.8 Coated Steel
8	Filter	AISI 302
9	Nut	8.8 Coated Steel

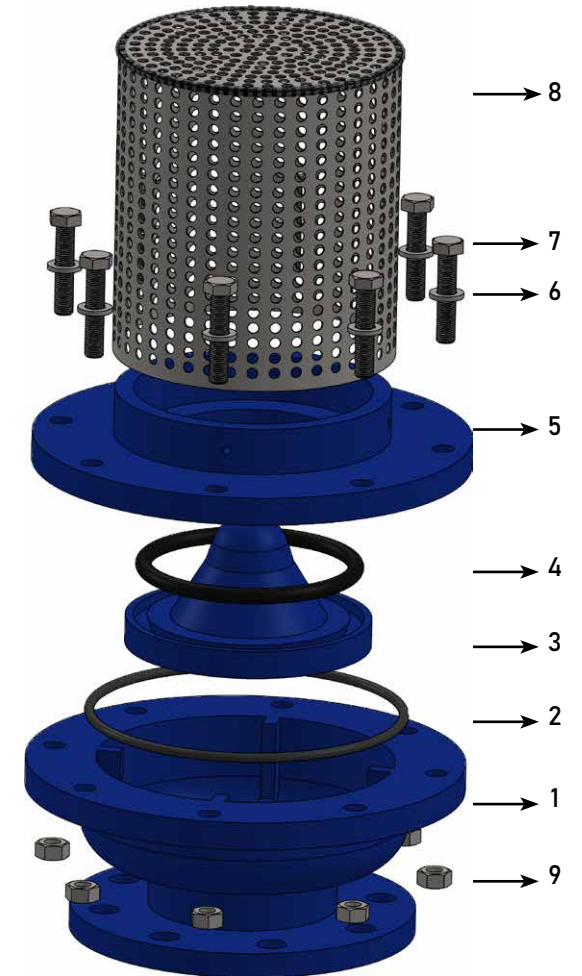



# Trade Fairs





Kemalpaşa OSB Mahallesi Kuzey Sanayi Caddesi  
Dış Kapı No:13  
Kemalpaşa / İzmir

+90 232 458 49 99  
+90 232 458 57 67

TYPHOON®

[www.tayfursu.com.tr](http://www.tayfursu.com.tr) | [info@tayfursu.com.tr](mailto:info@tayfursu.com.tr)

Her  
Fabrika  
Bir  
Kaledir\*

*H. Atatürk*



\* Every factory is a fortress